

| Order Qty | Pg # | Part # | Description | Category |
|-----------|------|------------|--|-----------------------------|
| | 2 | RFCB6H1 | Corner Bracket | Floor Mount Stainless Steel |
| | 2 | RZ0501 | 1" High Z-Bracket | Floor Mount Stainless Steel |
| | 2 | RZ1001 | 2" High Z-Bracket | Floor Mount Stainless Steel |
| | 2 | RFR90CBG1 | 90" Ratchet Strap w-Corner Bracket, Gray | Floor Mount |
| | 3 | RFR30G1 | 30" Ratchet Strap, Gray | Floor Mount |
| | 3 | RFR60G1 | 60" Ratchet Strap, Gray | Floor Mount |
| | 3 | RFR90G1 | 90" Ratchet Strap, Gray | Floor Mount |
| | 3 | RFR180G1 | 180" Ratchet Strap, Gray | Floor Mount |
| | 3 | RW1S2X1 | Flammable Cabinet Strut Fastener | Wall Mount |
| | 4 | RW1X48B21 | Wall Strap w-Side Release Buckle, Black | Wall Mount |
| | 4 | RW1X48G21 | Wall Strap w-Side Release Buckle, Gray | Wall Mount |
| | 4 | RW2X12B1 | FileSTRAP, Black | Wall Mount |
| | 4 | RW2X12G1 | FileSTRAP, Gray | Wall Mount |
| | 4 | RG2X14B21 | Ganging File Strap, Black | Wall Mount |
| | 4 | RG2X14G21 | Ganging File Strap, Gray | Wall Mount |
| | 5 | RW2X48B21 | Equipment Wall Strap, Black | Wall Mount |
| | 5 | RW2X48W21 | Equipment Wall Strap, White | Wall Mount |
| | 5 | RWCTWB1 | Cart-to-Wall Strap, Black | Wall Mount |
| | 5 | RWCTWG1 | Cart-to-Wall Strap, Gray | Wall Mount |
| | 5 | RWSS2X48B1 | StrutSTRAP w/Side Release Buckle, Black | Wall Mount |
| | 5 | RWSS2X48W1 | StrutSTRAP w/Side Release Buckle, White | Wall Mount |
| | 6 | RWSS32HG21 | 32" Strut Straps, Gray | Wall Mount |
| | 6 | RQ4X3P1 | 4x3 Adhesive Plate Assembly | Wall Mount |
| | 6 | RQ4X4P1 | 4x4 Adhesive Plate Assembly | Wall Mount |
| | 6 | 2930 | 4" Steel Furniture Cable | Wall Mount |
| | 7 | RDT24B1 | Equipment Fastener < 25 lbs, Black | Counter Top Equipment |
| | 7 | RDT24G1 | Equipment Fastener < 25 lbs, Gray | Counter Top Equipment |
| | 7 | RDT44B1 | Equipment Fastener < 50 lbs, Black | Counter Top Equipment |
| | 7 | RDT44G1 | Equipment Fastener < 50 lbs, Gray | Counter Top Equipment |
| | 7 | RDT64B1 | Equipment Fastener < 200 lbs, Black | Counter Top Equipment |
| | 7 | RDT64G1 | Equipment Fastener < 200 lbs, Gray | Counter Top Equipment |
| | 7 | RDT64W1 | Equipment Fastener < 200 lbs, White | Counter Top Equipment |
| | 8 | RDHP2G1 | HPLC 2-Stack Fastener Kit, Gray | Counter Top Equipment |
| | 8 | RDHP3G1 | HPLC 3-Stack Fastener Kit, Gray | Counter Top Equipment |
| | 8 | RDHP4G1 | HPLC 4-Stack Fastener Kit, Gray | Counter Top Equipment |
| | 8 | RDHP5G1 | HPLC 5-Stack Fastener Kit, Gray | Counter Top Equipment |
| | 8 | RDHP6G1 | HPLC 6-Stack Fastener Kit, Gray | Counter Top Equipment |
| | 8 | RDHP7G1 | HPLC 7-Stack Fastener Kit, Gray | Counter Top Equipment |
| | 8 | RDHP8G1 | HPLC 8-Stack Fastener Kit, Gray | Counter Top Equipment |
| | 9 | RDSG1 | LassoSTRAP for equipment < 25 lbs, Gray | Counter Top Equipment |
| | 9 | RDSL1 | LassoSTRAP for equipment < 50 lbs., Gray | Counter Top Equipment |
| | 9 | RDG141 | Gel Pad Fastener Kit | Specialty |
| | 10 | RWFX51 | Fire Extinguisher Strap | Specialty |
| | 10 | 4520 | Flat Screen TV Safety Strap | Specialty |
| | 10 | RSRDL1 | Refrigerator/Freezer Door Lock | Specialty |



Laboratory



University



Life Science

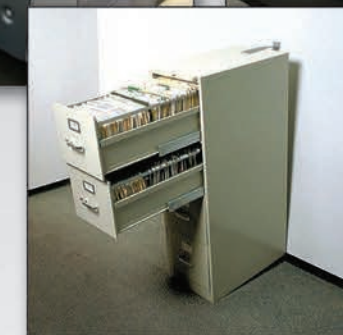

Corporate



Hospital



www.ReadyAmerica.com
1-800-959-4053
Escondido, CA 92029

Ready America, Inc. and READY AMERICA products are not affiliated in any way with the United States Department of Homeland Security or its READY.GOV programs, either in print or on the Internet.

FASTENERS FOR SEISMIC BRACING

WHAT ARE YOU REQUIRED BY CODE TO BRACE?

Title 24

Section 1613A "Lateral Force on Elements of Structures, Nonstructural Components and Equipment Supported by Structures" "Elements of structures and their attachments, permanent nonstructural components and their attachments, and the attachments for permanent equipment supported by a structure shall be designed to resist the total design seismic forces prescribed in Section 1632.A.2. Attachments shall include anchorages and required bracing."

Non-Structural Items Requiring Proper Bracing (partial list):

1. Movable items (storage racks, etc.) that are 5 feet and taller must be seismically braced. Anything less than 5 feet in height must be braced if the supporting base is less than two-thirds of the overall height of the unit. All such items shall be restrained to prevent movement when not in use.
2. Permanent floor-supported items (cabinets, bookcases, etc.) that are more than 6 feet in height (including contents).
3. All equipment greater than 400 lbs, and greater than 4 feet in height need to be properly braced for lateral loads. (ASCE 7-05 Section 13.1.4)
4. Temporary containers with flammable or hazardous materials.
5. Vessels, including tanks and pressurized spheres on braced or un-braced legs.
6. Bins or hoppers on braced or un-braced legs.
7. Batteries on racks shall be restrained against movement in all directions due to earthquake forces.
8. All other self-supporting structures not otherwise covered.

Creating a Secure Environment

When an earthquake strikes, the primary cause of injury or death is from unsecured heavy objects toppling over. The first step in earthquake preparedness is to secure top heavy items such as furniture, storage cabinets, data cabinets, expensive equipment and items that if damaged would cause operations to cease. Hospitals, universities, laboratories, offices, and warehouses each have special needs for earthquake bracing. This product assortment offers fasteners designed to meet and exceed all of those needs.



Floor Mount Stainless Steel

Corner Bracket

Part # RFCB6H1

Kit Contains:

- 1) stainless steel corner bracket, 1/4" thick, 6" high
 - 2) 3/8" drop anchors
 - 2) 3/8" anchor bolts
 - 2) 3/8" washers
- Instructions



Used for: Equipment with round legs or square legs or corners without legs.

1" High Z-Bracket

Part # RZ0501

2" High Z-Bracket

Part # R1001

Kit Contains:

- 1) Z-bracket
 - 2) 3/8" drop anchors
 - 2) 3/8" anchor bolts
 - 2) 3/8" washers
- Instructions



Used for: Equipment with adjustable legs.

Floor Mount

90" Ratchet Strap w/Corner Brackets

Color: Gray

Part # RFR90CBG1

Kit Contains:

- 1) 2" x 90" strap w/wide-handle ratchet and floor-mount plate
 - 1) 2" x 180" strap w/floor-mount plate
 - 2) Corner brackets
 - 2) 3/8" drop anchors
 - 2) 3/8" anchor bolts
 - 2) 3/8" washers
- Instructions

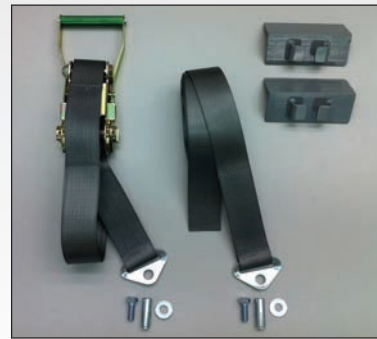

Used for: Multi-door refrigerators, freezers, shakers, incubators and other large floor equipment. 4,000 lb break strength.

Floor Mount

Ratchet Straps



Used for: Multi-door refrigerators, freezers, shakers, incubators and other large floor equipment. 4,000 lb break strength.

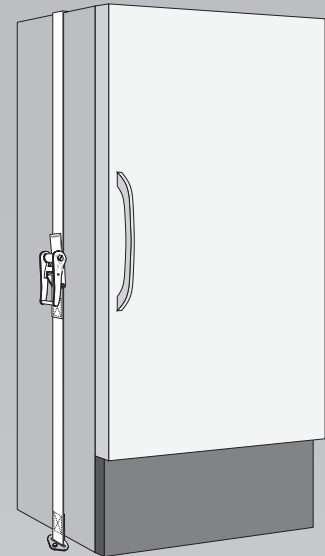

30" Ratchet Strap

Color: Gray
Part # RFR30G1

Kit Contains:

- 1) 2" x 30" strap w/wide-handle ratchet and floor-mount plate
- 1) 2" x 180" strap w/floor-mount plate
- 2) 3/8" drop anchors
- 2) 3/8" anchor bolts
- 2) 3/8" washers
- Instructions

60" Ratchet Strap

Color: Gray
Part # RFR60G1

Kit Contains:

- 1) 2" x 60" strap w/wide-handle ratchet and floor-mount plate
- 1) 2" x 180" strap w/floor-mount plate
- 2) 3/8" drop anchors
- 2) 3/8" anchor bolts
- 2) 3/8" washers
- Instructions

90" Ratchet Strap

Color: Gray
Part # RFR90G1

Kit Contains:

- 1) 2" x 90" strap w/wide-handle ratchet and floor-mount plate
- 1) 2" x 180" strap w/floor-mount plate
- 2) Corner brackets
- 2) 3/8" drop anchors
- 2) 3/8" anchor bolts
- 2) 3/8" washers
- Instructions

180" Ratchet Strap

Color: Gray
Part # RFR180G1

Kit Contains:

- 1) 2" x 180" strap w/wide-handle ratchet and floor-mount plate
- 1) 2" x 180" strap w/floor-mount plate
- 2) 3/8" drop anchors
- 2) 3/8" anchor bolts
- 2) 3/8" washers
- Instructions

Wall Mount

Flammable Cabinet Strut Fastener

Color: Gray
Part # RW1S2X1

Kit Contains Struts:

- 1) 40" strut (white powder-coat)
- 2) strut end caps (white)
- 2) 1/4" wood stud screws
- 2) 1/4" metal stud togglers
- 2) 1/4" metal stud screws
- 2) 1/4" x 1" washers
- Strut to Wall Instructions

Kit Contains Strut Straps:

- 2) 2" x 16" strut straps w/industrial VELCRO® brand hook & loop and metal mounting bracket
- 2) 3/8" strut-washer nuts
- 2) 3/8" x 1" 16-tip Grade 5 bolts
- 2) 3/8" flat washers
- 2) Surface prep pads
- Instructions

Used for: Securing flammable and toxic corrosives cabinets to wall stud w/industrial Hook & Loop to avoid penetrating cabinet with screws.



Wall Mount

Wall Strap w/Side Release Buckle

Color: Black
Part # RW1X48B21

Color: Gray
Part # RW1X48G21

Kit Contains:

- 2) 1" x 48" straps using a steel plate w/3M® VHB adhesive & steel buckle
- 2) 1/4" metal stud togglers w/instructions
- 2) 1/4" metal stud screws
- 2) 1/4" wood stud screws
- 2) 1/4" x 1" washers
- 2) surface prep pads
- Instructions

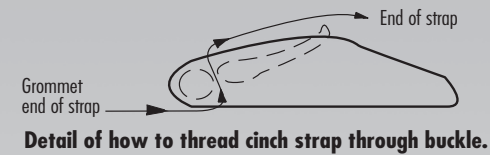
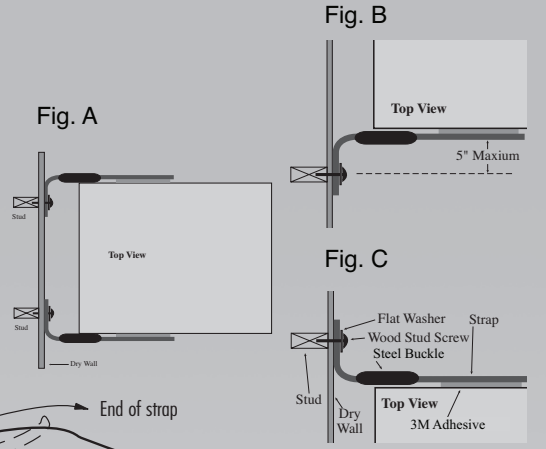
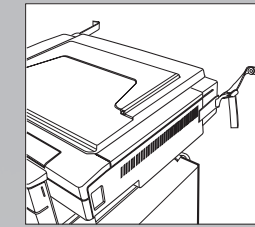

Used for: Copiers and other medium sized equipment. Easy release.

FileSTRAP

Color: Black
Part # RW2X12B1

Color: Gray
Part # RW2X12G1

Kit Contains:

- 1) 2" x 12" strap w/industrial VELCRO® brand hook and loop
- 1) 1/4" metal stud toggler w/instructions
- 1) 1/4" metal stud screw
- 1) 1/4" wood stud screw
- 1) 1/4" x 1" washer
- 1) surface prep pad Instructions

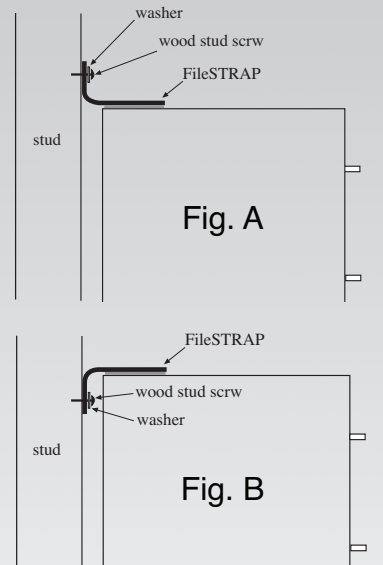
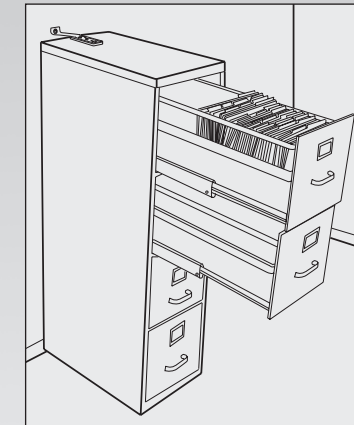

Used for: File cabinets, storage cabinets, bookshelves and other similar cabinets.

Ganging File Strap

Color: Black
Part # RG2X14B21

Color: Gray
Part # RG2X14G21

Kit Contains:

- 2) 2" x 14" straps w/industrial VELCRO® brand hook and loop on each side
- 4) Surface prep pads
- Instructions

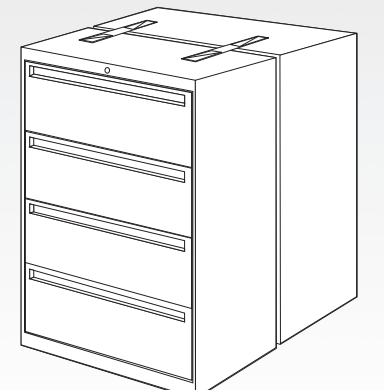

Used for: Ganging together file cabinets, storage cabinets, bookshelves and other similar items.

Wall Mount

Equipment Wall Strap

Color: Black
Part # RW2X48B21

Color: White
Part # RW2X48W21

Kit Contains:

- 2) 2" x 48" straps w/industrial VELCRO® brand hook and loop w/side-release buckle
- 2) 1/4" wood stud screws
- 2) 1/4" metal stud togglers w/instructions
- 2) 1/4" metal stud screws
- 2) 1/4" x 1" washers
- 2) surface prep pads
- Instructions

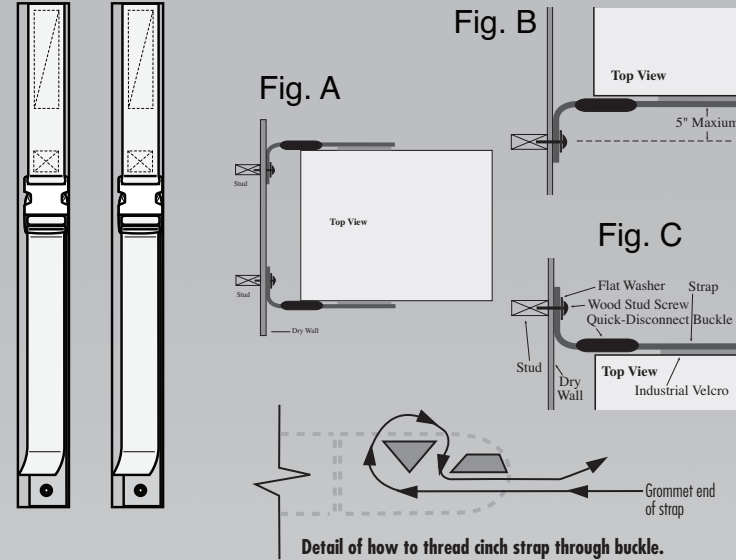

Used for: Kitchen-size freezers, refrigerators, incubators, centrifuges and similar sized items.

Cart-to-Wall Strap

Color: Black
Part # RWCTWB1

Color: Gray
Part # RWCTWG1

Kit Contains:

- 1) 16" strap w/D-rings
- 1) 8" strap w/quickdisconnect buckle
- 1) 1/4" wood stud screw
- 1) 1/4" metal stud toggler w/instructions
- 1) 1/4" metal stud screw
- 1) 1/4" x 1" washer
- Instructions

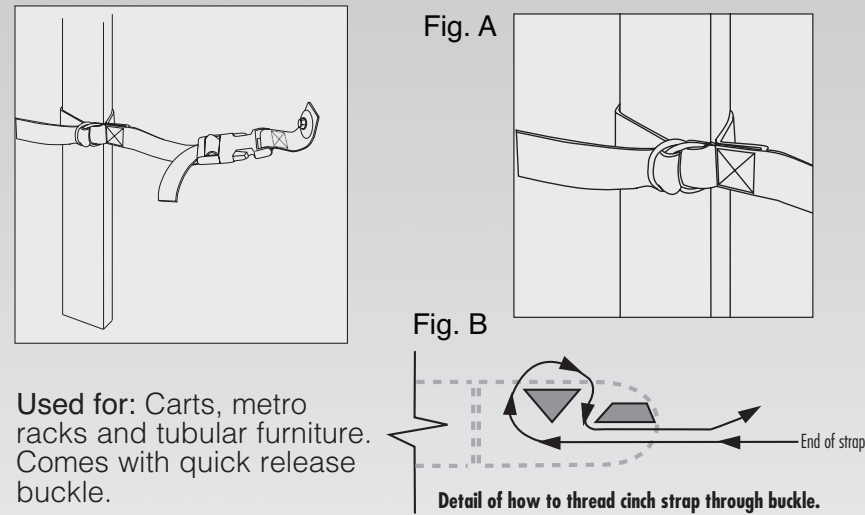

Used for: Carts, metro racks and tubular furniture. Comes with quick release buckle.

Small Refrigerator/Freezer StrutSTRAP w/Side Release Buckle

Color: Black
Part # RWSS2X48B1

Color: White
Part # RWSS2X48W1

Kit Contains:

- 2) 2" x 48" straps w/industrial VELCRO brand hook and loop w/side-release buckle
- 2) 3/8" strut-washer nuts
- 2) 3/8" x 1" bolts
- 2) 3/8" x 1-1/2" flat washers
- 2) Surface prep pads
- Instructions

Used for: Securing kitchen sized refrigerators, freezers and similar sized items to existing 1-5/8" strut on wall. Comes with quick release buckle.

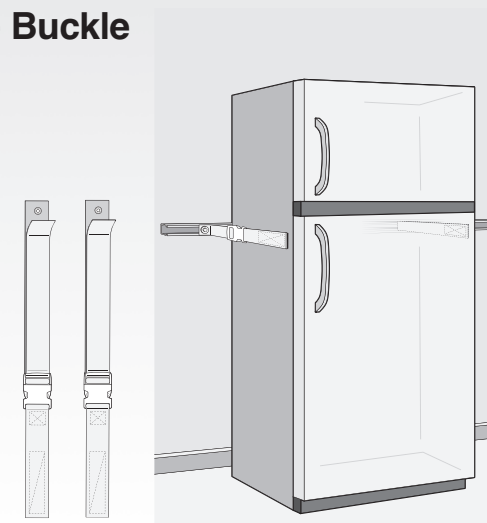

32" StrutSTRAP

Color: Gray
Part # RWSS32HG21

Kit Contains:

- 2) 2" x 13" straps w/industrial VELCRO® brand hook and loop
- 2) 19" cables w/mounting bracket & quick link
- 2) 3/8" strut-washer nuts
- 2) 3/8" x 1" bolts
- 2) 3/8" x 1" flat washers
- 2) Surface prep pads
- Instructions

Used for: Securing multi-door refrigerators, freezers, shakers, incubators and other large equipment to existing 1-5/8" strut on wall. Easy disconnect.

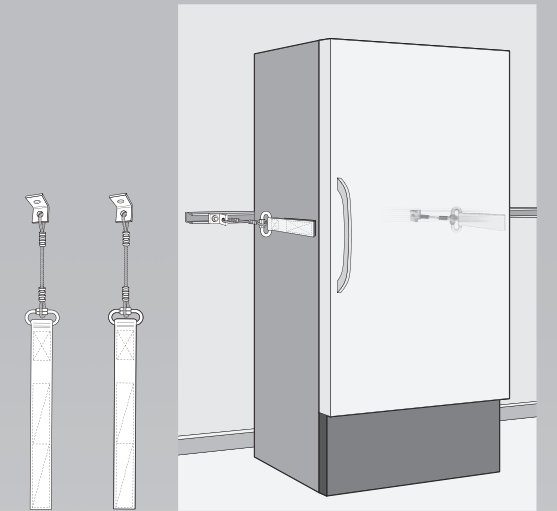

4" x 3" Adhesive Plate Assembly

Part # RQ4X3P1

Kit Contains:

- 1) 4" x 3" plate with 1/2" loop and 3M® VHB adhesive
- 2) Surface prep pads
- Instructions

Used for: Securing kitchen size refrigerators, freezers and similar sized items, as well as large counter top equipment with customer provided cable and anchors.

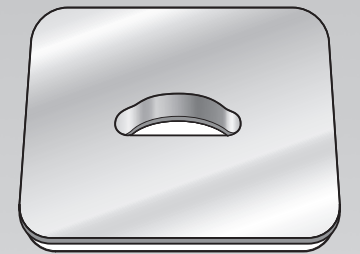

4" x 4" Adhesive Plate Assembly

Part # RQ4X4P1

Kit Contains:

- 1) 4" x 4" plate with cable and 3M® VHB adhesive
- 2) Surface prep pads
- Instructions

Used for: Securing kitchen size refrigerators, freezers and similar sized items, as well as large counter top equipment with customer provided anchors.

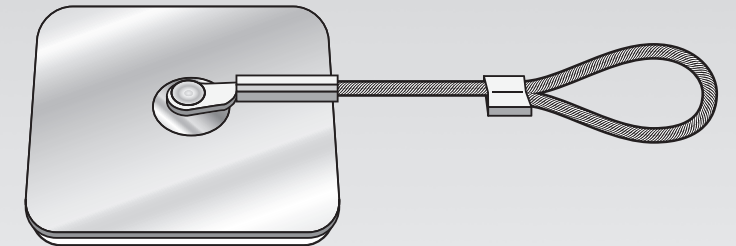

4" Steel Furniture Cable

Part # 2930

Kit Contains:

- 2) End Cap
- 1) 4" Cable
- 1) Furniture Plate
- 1) Wall Plate
- 2) 1-1/2" Screws
- 1) 2" Screw
- Instructions

Used for: Securing tall and top-heavy furniture to the wall. 1,000 lb break strength.

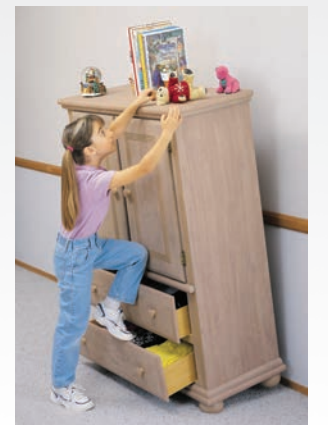
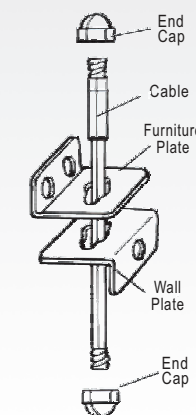

Counter Top Equipment

Equipment Fasteners

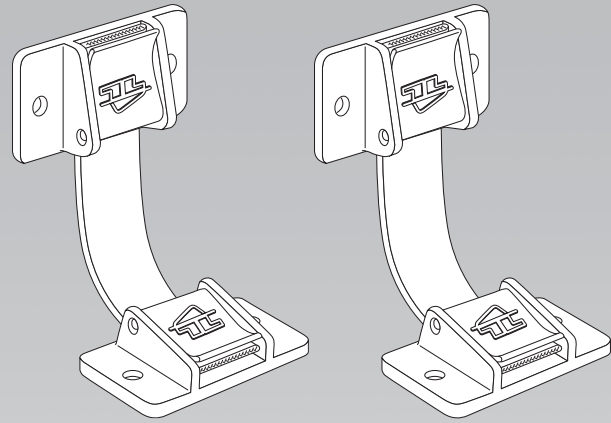

Used for: Countertop and desktop equipment.

1" x 2" for equipment less than 25 lbs.

Color: Gray
Part # RDT24B1

Color: Black
Part # RDT24G1

Kit Contains:

- 4) 1" x 2" buckles w/3M® VHB adhesive
- 2) 3/4" x 4" Locking Straps
- 2) Surface prep pads
- Instructions

2" x 2" for equipment less than 50 lbs.

Color: Black
Part # RDT44B1

Color: Gray
Part # RDT44G1

Kit Contains:

- 4) 2" x 2" buckles w/3M® VHB adhesive
- 2) 1" x 5" Locking Straps
- 2) Surface prep pads
- Instructions

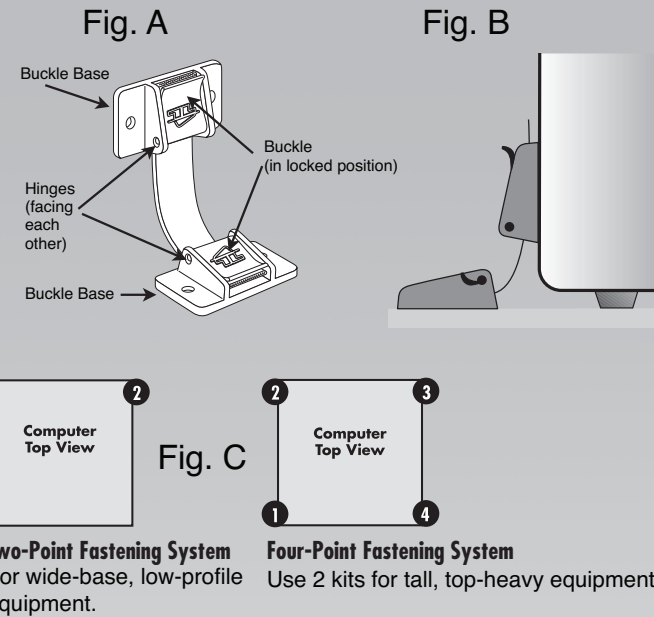

2" x 3" for equipment less than 200 lbs.

Color: Black
Part # RDT64B1

Color: Gray
Part # RDT64G1

Color: White
Part # RDT64W1

Kit Contains:

- 4) 2" x 3" buckles w/3M® VHB adhesive
- 2) 1" x 8" Locking Straps w/holes
- 2) Surface prep pads
- Instructions

HPLC Stack Fastener Kits

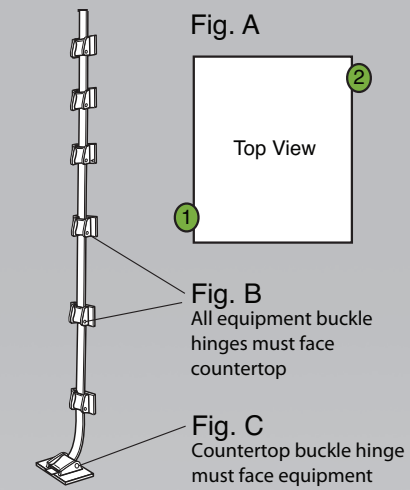
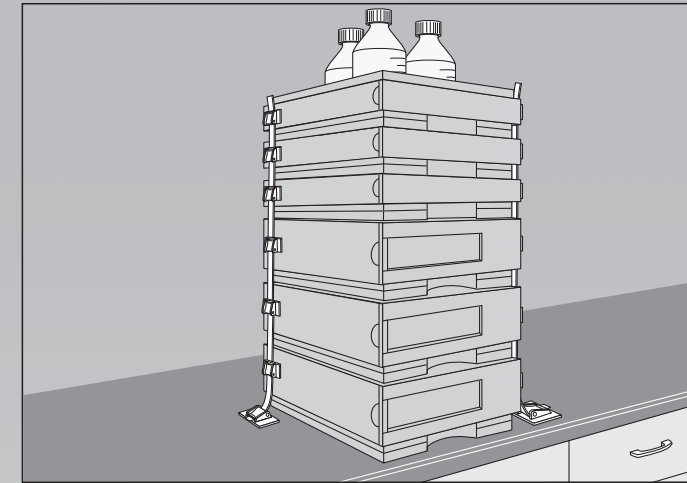

Used for: Countertop and desktop stacked equipment.

2 Stack

Color Gray
Part # RDHP2G1

Kit Contains Two Fastener Assemblies:

- 2) 2" x 2" countertop buckles w/3M® VHB adhesive
- 4) 1" x 2" equipment buckles w/3M VHB adhesive
- 2) 12" coated Locking Straps
- 4) Surface prep pads
- Instructions

3 Stack

Color Gray
Part # RDHP3G1

Kit Contains Two Fastener Assemblies:

- 2) 2" x 2" countertop buckles w/3M® VHB adhesive
- 6) 1" x 2" equipment buckles w/3M VHB adhesive
- 2) 16" coated Locking Straps
- 6) Surface prep pads
- Instructions

4 Stack

Color Gray
Part # RDHP4G1

Kit Contains Two Fastener Assemblies:

- 2) 2" x 2" countertop buckles w/3M® VHB adhesive
- 8) 1" x 2" equipment buckles w/3M VHB adhesive
- 2) 20" coated Locking Straps
- 8) Surface prep pads
- Instruction

5 Stack

Color Gray
Part # RDHP5G1

Kit Contains Two Fastener Assemblies:

- 2) 2" x 2" countertop buckles w/3M VHB adhesive
- 10) 1" x 2" equipment buckles w/3M VHB adhesive
- 2) 24" coated Locking Straps
- 10) Surface prep pads
- Instructions

6 Stack

Color Gray
Part # RDHP6G1

Kit Contains Two Fastener Assemblies:

- 2) 2" x 2" countertop buckles w/3M VHB adhesive
- 12) 1" x 2" equipment buckles w/3M VHB adhesive
- 2) 28" coated Locking Straps
- 12) Surface prep pads
- Instructions

7 Stack

Color Gray
Part # RDHP7G1

Kit Contains Two Fastener Assemblies:

- 2) 2" x 2" countertop buckles w/3M VHB adhesive
- 14) 1" x 2" equipment buckles w/3M VHB adhesive
- 2) 32" coated Locking Straps
- 14) Surface prep pads
- Instructions

8 Stack

Color Gray
Part # RDHP8G1

Kit Contains Two Fastener Assemblies:

- 2) 2" x 2" countertop buckles w/3M VHB adhesive
- 16) 1" x 2" equipment buckles w/3M VHB adhesive
- 2) 36" coated Locking Straps
- 16) Surface prep pads
- Instructions

Counter Top Equipment

LassoSTRAP for equipment less than 25 lbs.

Color: Gray
Part # RDSG1

Kit Contains:

- 1) 1" x 2" buckle w/3M® VHB adhesive
- 1) 3/4" x 30" Locking Strap w/D-ring
- 2) Surface prep pads
- Instructions

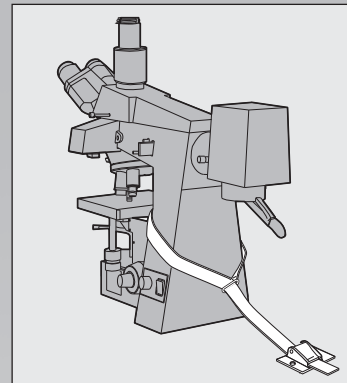

LassoSTRAP for equipment less than 50 lbs.

Color: Gray
Part # RDSL1G1

Kit Contains:

- 1) 2" x 2" buckle w/3M® VHB adhesive
- 1) 1" x 30" Locking Strap w/D-ring
- 2) Surface prep pads
- Instructions

Fig. A

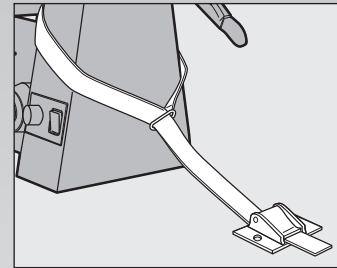

Used for: Countertop and desktop pedestal equipment.

Specialty

Gel Pad Fastener Kit

Color: Clear
Part # RDG141

Kit Contains:

- 4) 1" x 1" two-sided fasteners
- 2) Surface prep pads
- Instructions



Used for: Flat-bottomed equipment weighing less than 25 lbs.

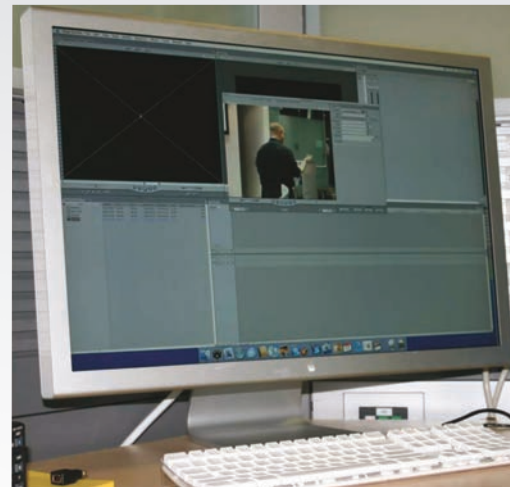
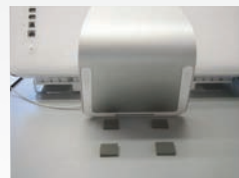

Fire Extinguisher Strap

Color: Red/Yellow
Part # RWFX51

Kit Contains:

- 1) fire extinguisher strap
- 1) 1/4" metal stud toggler w/instructions
- 1) 1/4" metal stud screw
- 1) 1/4" wood stud screw
- 1) 1/4" x 1" washer
- Instructions

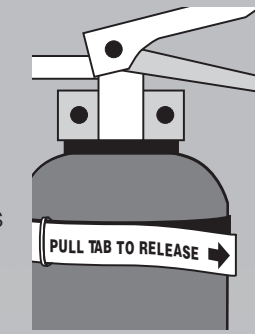
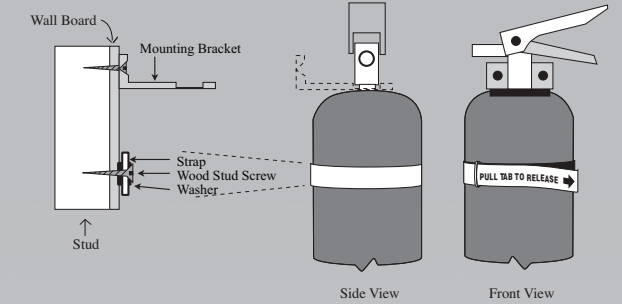

Fig. A



Used for: 5" diameter fire extinguishers

Flat Screen TV Strap

Color: Black
Part # 4520

Kit Contains:

- 2) 1" x 18" straps
- 2) Buckles (2" x 2") with 3M® adhesive
- 2) 8mm x 20mm machine screw, 2) 8mm washers
- 2) 6mm x 16mm machine screw, 2) 6mm washers
- 2) wood screws, 2) alcohol pads • 1/4 oz. putty
- 2) surface prep pads • Instructions

Fig. A

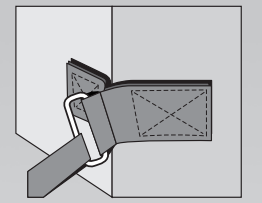
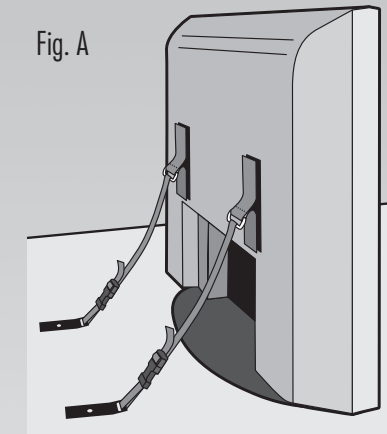

Designed to adhere to flat, curved, or corner surfaces.

Used for: Flat screen TVs, plasma & LCD TVs and large flat screen monitors.

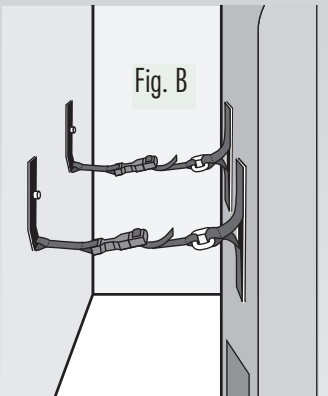
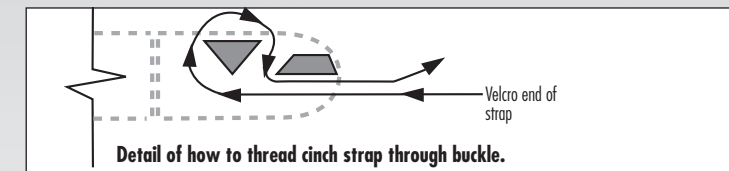

Fig. B

Refrigerator/Freezer Door Lock

Part # RSRDL1

Kit Contains:

- 1) Door Lock w/3M® VHB adhesive
- 2) Surface prep pads
- Instructions

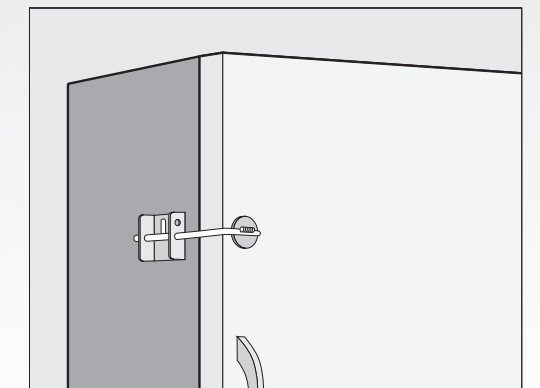

Used for: Keeping refrigerator and freezer doors from coming open.