



www.QuakeHOLDIndustrial.com

**Corporate Office:**  
1150 Simpson Way, Escondido, CA 92029  
760-466-1060

**Los Angeles Office:**  
411 S. Vermont Ave, Glendora, CA 91741  
626-852-8800

**San Francisco Bay Area Office:**  
22113 Queen Street, Castro Valley, CA 94546  
800-959-4053

# DIAGONAL FLOOR BRACING

## Seismic Diagonal Bracing

### Part #: CUSTOM

### General Information

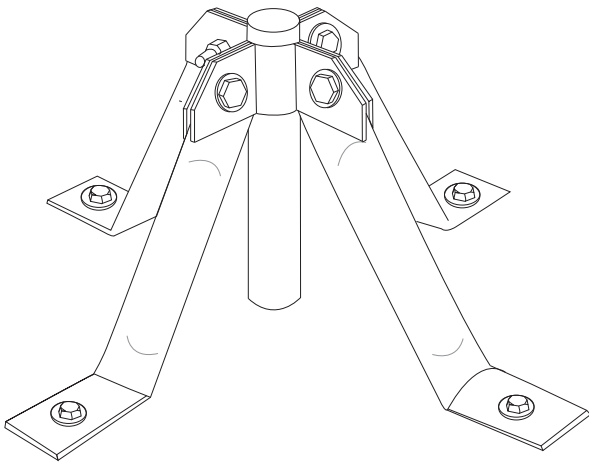

The majority of computer room floors are raised from 6" to 24", with 8" to 12" being average.

Due to the large amount of equipment and the attending weight resting on the suspended floor, the potential exists for the entire floor to suddenly shift one way or the other during an earthquake. This could cause the floor to collapse, damage to valuable equipment, and/or breakage of air-handler liquid lines.

In addition, glass walls around the perimeter of suspended floors are prime targets for shattering during floor shift and are a hazard to personnel.

We recommend seismically bracing all suspended floors 8" in height and above.

- Purpose:
- 1) To minimize personnel hazard.
  - 2) To minimize equipment damage.
  - 3) To increase your potential to be up and running after an earthquake.

### Placement of Braces Under Access Floor

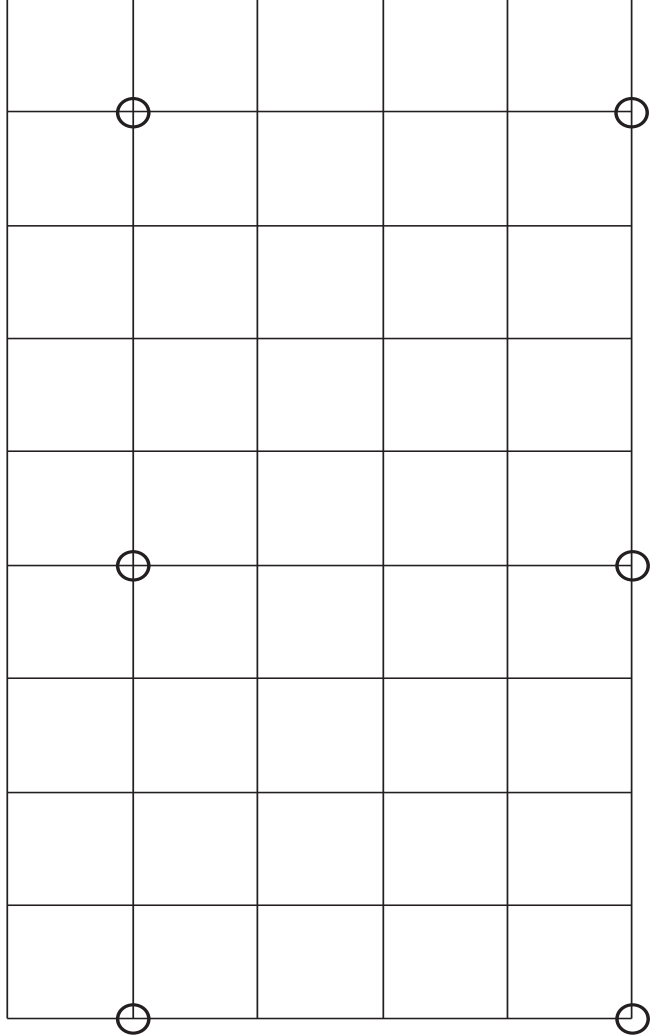

The braces should be placed at a minimum distance of four (4) tiles apart in both the north-to-south and east-to-west directions. For standard computer floor tiles, 24" x 24", this would be every eight feet (see diagram above).