



Corporate Office:

1150 Simpson Way
Escondido
California
92029
760-466-1060
760-466-1057 fax
www.QuakeHOLDIndustrial.com

Los Angeles Office:

411 S. Vermont Avenue
Glendora
California
91741
626-852-8800
626-852-8801 fax

**San Francisco Bay Area
Office:**

22113 Queen Street
Castro Valley
California
94546
800-959-4053
510-363-8067 fax

Cart-to-Wall Strap

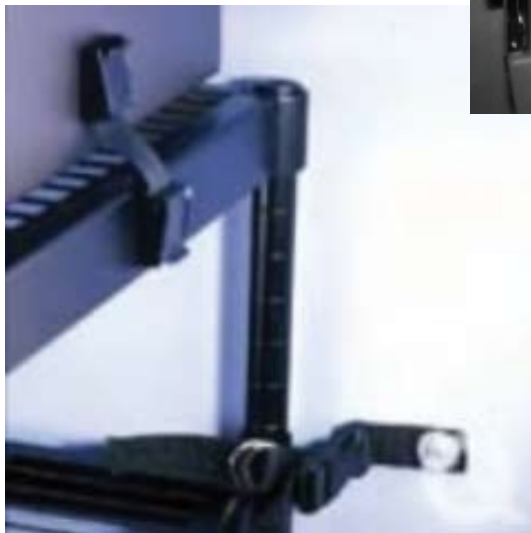
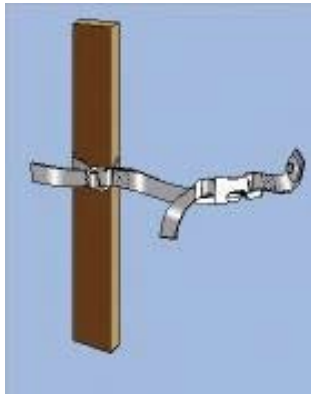

One end secures to a leg or post with a D-ring cinch strap. The other end is secured to a wall stud. Between the two is a quick-disconnect buckle. The strap can be adjusted from 10" to 24" inches of slack. Use on TV carts, audio/visual carts, medical carts, bakers' racks, or any item on wheels.